

# MaticFire 24 combinato

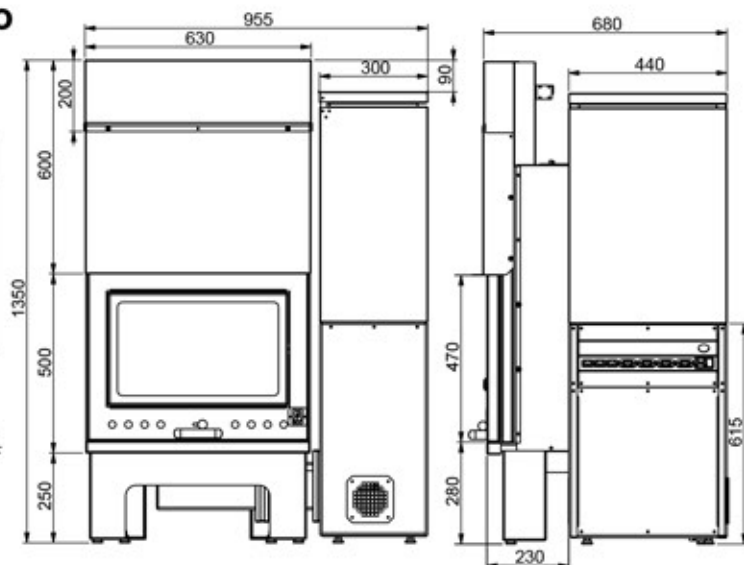

**VCR**

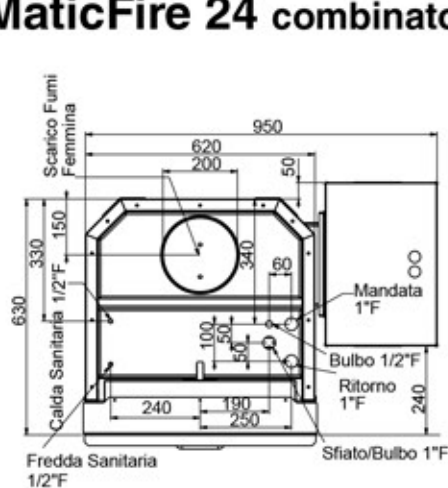

**MF24**

Potenza termica nominale a pellet <i>Thermal nominal power with pellets</i>	kW	24
Potenza termica nominale a legna <i>Thermal nominal power with wood</i>	kW	21
Resa all'acqua a pellet / a legna <i>Water power with pellets / wood</i>	kW	- 21 / 18
Rendimento <i>Output</i>	%	- 83
Consumo orario [pellet / legna] <i>Hourly consumption [pellet / wood]</i>	Kg/h	[0,5 - 6] / [1 - 7]
Dimensione canna fumaria <i>Dimension of chimney</i>	Ø cm	20
Dimensioni camera di combustione <i>Dimensions combustion chamber</i>	cm	55 x 52 x 30 h
Tiraggio minimo canna fumaria <i>Minimum sucking of chimney</i>	Pa	10 a freddo
Capacità serbatoio pellet <i>Capacity of pellet tank</i>	Kg	55
Produzione acqua calda sanitaria $\Delta t=25^{\circ}\text{C}$ <i>Production of domestic hot water <math>\Delta t=25^{\circ}\text{C}</math></i>	l/min	10
Peso <i>Weight</i>	Kg	-285

\*tasto manuale - manual button

Rivestimento Corten.  
*Corten covering.*

I colori e le finiture qui riportati devono ritenersi puramente indicativi.  
*Colours and finishes shown here are merely indicative.*



SCHEDE TECNICHE