

MatriX | 800/650 III

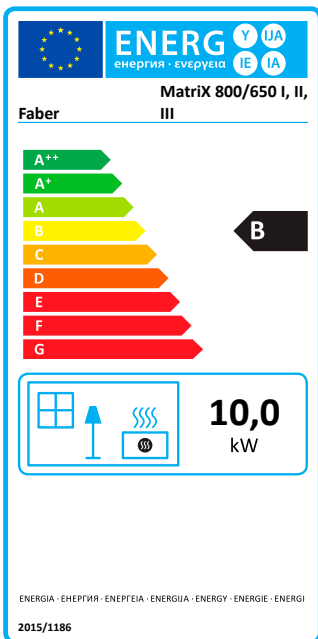
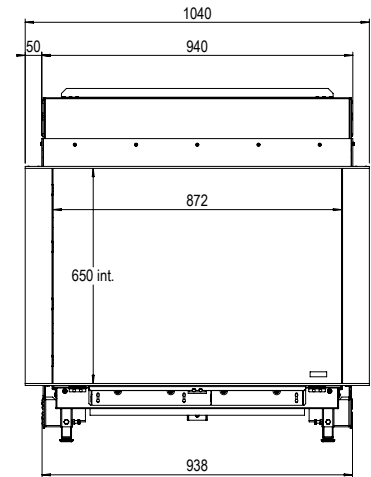
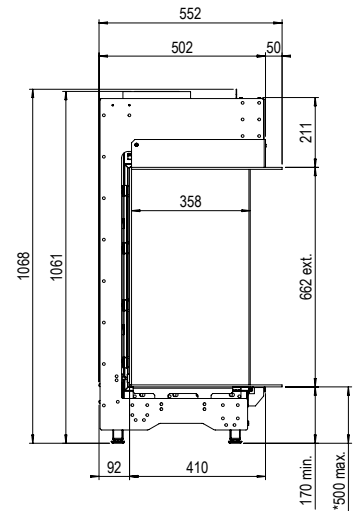
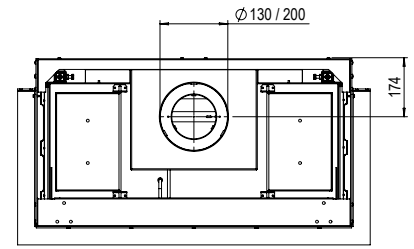

Specifications MatriX 800/650 III

Type	Built-in
Model	Three-sided model
Exterior dimensions WxHxD in mm	1040 x 1068 x 552
Fire display WxHxD in mm	872 x 650 x 358
System	Log Burner 2.0®
Decoration	Log set
Back walls	Smooth steel
Remote	ITC remote
Power (kW)	10,0
Operating system	Honeywell
Energy label	B

OPTIONS

- Glass back wall black
- Anti-reflective glass
- Symbio Module
- Wall bracket
- Adjustable legs

Depth frame 100mm will be available again in 2021. Faber will inform you when the frame becomes available in due course.

There is **so much to tell...**

For more information, please take a look at the website

www.faberfires.com